

For Quick View mode, look for the
Thumbnail Icon () above your Screen.

Power Meters

The Power Meters *Online Catalogue* is New.
It falls under Section 9 which is a new Section.

This section and its products will be added
into the Main Mimic Catalogue in due course.

SECTION

9

SECTION 9
POWER METERS



- ❖ Power Logging Meters, Analysers, Integrators for Electrical, Solar, & alternate Networking Systems.
- ❖ Real-time measurements Current, Voltage, when converting from Electrical to Solar Applications.
- ❖ Power Panel Meters DIN Rail Mounting.
- ❖ Power Event Recording, Processing, Ethernet.
- ❖ Rogowski Coils
- ❖ Integrators & Amplifiers.

Johannesburg Branch



Cape Town Branch



INDEX

Power Logging Meters, Analysers, Integrators for Electrical, Solar & Other Networking Solutions

SECTION 1

1. **ME237 Panel Meter** 01

Application: Panel Meter. ME237 panel type three-phase multi-functional power meter.

Supports direct current input or external open-ended Rogowski coil or voltage type CT for wire free tests.

It also supports three-phase three wire and three-phase four wire systems, measuring current, voltage, power factor, harmonic, power, energy.

SECTION 2

1. **ME440 Handheld Data Logger**02

Application: Current & Voltage power meter. Ideal for power efficiency to solar or other power installations.

SECTION 3

1. **ME435 Three-Phase Handheld Power Meter**03

Application: Assessing Solar Power Installations.

Electrical power logging meter when converting from electricity to solar to analyse power consumption for correct solar sizing after electric conversion to solar.

SECTION 4

1. **MQ21 Event Recorder. Power Quality Analyser**04

Solar Grid Connected PV Generation Systems. DIN Rail Mounting

Application: Power Quality Analysis and Consumption. Solar Grid-Connected PV Generation System, Consumption, Event Recorder and Multifunction Fault Recorder.

SECTION 5

1. **MQ21-4G Edge Processing Gateway**05

Application: MQ21-4G is used to connect the MQ21 device to the Internet via mobile phone network.

Works with other intelligent power acquisition equipment and electricity meters.

Suitable for energy consumption monitoring and power quality analysis of electrical parameters.

Collects waveform data and event data in real time.

Analyses power in real time.

SECTION 6

1. **PQ-4G Ethernet Edge Computing Gateway**06

Application: Ethernet edge computing Gateway. 4G Gateway Wireless Transceiver Module and Wireless Radio Modules.

Can also be used with and operates with intelligent power acquisition equipment and electricity meters.

It is suitable for energy consumption monitoring and power quality analysis of electrical parameters, collects waveform data and event data in real time, and analyses the power via Cloud in real time.

2. **4G Module and Energy Quality Monitoring Platform**07

3. **Real-time Online Energy Quality Monitoring Platform (EQMP)**07

Application: Real-Time Online Cloud Platform for Energy Quality.

INDEX

SECTION 7

1. TABLE: Power Meters08
2. ME437 : ME631 : ME531 Three-Phase Power Meters08
3. TABLE: Function List09 & 10

Application: Power Analyses. Energy Meters.

SECTION 8

1. Rogowski Coils & Coil Models11
---------------------------------------	-----

Introduction: What is a Rogowski Coil?11
---	-----

Application: Rogowski coils are a current measuring system that consists of a coil and conditioning electronics.

Current transducers are used for AC measurements.

They can be used similarly to current transformers but with considerable advantages.

2. MRC Ø6 Flexible Rogowski Coil Fixed by Cable Ties12
--	-----

Application: Measuring devices, lab instrumentation.

Power monitoring & control systems. DC ripple measurement.

Harmonics and transients monitoring. Power meter, Power analyser sensor.

3. Y-FCT 08 Flexible Rogowski Coil12
--	-----

Application: Measuring devices, lab instrumentation.

Power monitoring & control systems.

DC ripple measurement Harmonics and transients monitoring. Power meter, Power analyser sensor.

SECTION 9

Integrators (Amplifiers)13
---------------------------------------	-----

Introduction: What does an Integrator do?13
--	-----

Application: As the Rogowski coil output is a weak voltage mV signal, an integrator is used for its ability to amplify and convert a weak voltage mV signal to a standard signal when used with a multi-meter and scope.

1. S9 Mini Integrator13
-----------------------------	-----

Application: Measuring devices. Power meter measurement. Harmonics and transients monitoring.

Welding machine control. High current measurement. PLC control.

2. S9.4 Waterproof integrator14
-------------------------------------	-----

Application: Measuring devices. Power meter measurement. Harmonics and transients monitoring.

Welding machine control. High current measurement. PLC control.

3. D1 Industrial integrator14
-----------------------------------	-----

Application: Measuring devices. Power monitoring & analysis. Harmonics and transients monitoring.

Welding machine control. High current measurement. PLC control.

4. S1 High Accuracy integrator15
--------------------------------------	-----

Application: Measuring devices, lab instrumentation. Power monitoring & control systems. Harmonics and transients monitoring. DC ripple measurement. Welding machine control. High current measurement.

5. DTP integrator15
-------------------------	-----

Application: Measuring devices, and lab instrumentation. Power monitoring & analysis. Harmonics and transients monitoring. Welding machine control. High current measurement.

6. DA01 integrator16
--------------------------	-----

Application: Measuring devices, and lab instrumentation. Power monitoring & analysis. Harmonics and transients monitoring. Welding machine control. High current measurement.

7. ATP01 integrator16
---------------------------	-----

Application: Measuring devices, lab instrumentation. Power monitoring & analysis. Harmonics and transients monitoring. Welding machine control. High current measurement.

8. A05 integrator17
-------------------------	-----

Application: Measuring devices, lab instrumentation. Power monitoring & analysis. Harmonics and transients monitoring. Welding machine control. High current measurement.

9. HF High Frequency integrator17
---------------------------------------	-----

Application: Measuring devices, lab instrumentation, Lightning protection. Lightning monitoring. Lightning current measurement. Pulse waveform analysis.

10. S2 integrator18
-------------------------	-----

Application: Measuring devices, lab instrumentation. Power monitoring & analysis. Harmonics and transients monitoring. Welding machine control. High current measurement.

Introduction

Mimic Components are the sole distributors of the *Meatrol* range of power logging and metering equipment.

We supply full technical support for:

- A) renewable energy conversion assessment (by using the ME 440 Power logger)
- B) in a plant we offer the ME237
- C) for Event Recording we offer MQ21

These are our popular products. We offer many others from the same company including hi-accuracy clip-on Roskowsky coils with signal integrators for use with SCADA and other applications.

ME237 Three-Phase Multi-functional Panel Meter

Application: Panel Meter

ME237 panel type three-phase multi-functional power meter. Supports direct current input or external open-ended Rogowski coil or voltage type CT for wire free tests. It also supports three-phase three wire and three-phase four wire systems, measuring current, voltage, power factor, harmonic, power, energy and other electrical parameters of A, B, C phase network.

The standard RS485 communication interface is compatible with various configuration systems through the standard Modbus RTU protocol. The electrical parameters collected by the front end can be transmitted to a system data centre in real time.

ME237 Product Characteristics

Type:	96*96 Panel Meter
Poles description:	3PH3W, 3PH4W
Application:	Current, Voltage, Power, Energy & Harmonic Measurement
Display Screen:	3.8 inch LCD segment code display screen
Weight:	259g
Dimensions:	L*W*D: 8. 1*8. 1*3CM
Colour:	White & Black

Features:

- Real-time data display
- Accuracy
- Certification
- Various power output connections
- Selectable operational interface displays

Supports:

- 3PH3W system
- 3PH4W system

Measures:

- Current
- Voltage
- Power Factor
- Harmonic
- Energy
- Other electrical parameters of L1, L2, and L3



ME23 STD Communications:

The standard RS485 communication interface is compatible with various configuration systems through the standard MODBUS-RTU protocol.

ME237 Same-Brand Compatibility:

Compatible with and supports same-branded products such as the ME237C (1/5A CTs), the ME237V (external 333mV CTs) and the ME237R (Flexible Rogowski Coil).

Add-On Products for ME237

The ME237 is available with a conventional CT interface or a direct connect Rogowski Interface. Mimic stock ME237C and ME237R & Rogowski Coils.

ME440 Handheld Data Logger

Application: Current & Voltage power meter. Ideal for power efficiency to solar or other power installations.

Features

- Direct reading of the neutral with an additional Rogowski coil and voltage clip.
- Lithium batteries give 10 hours of use before it is necessary to use the mains adaptor.
- Read up to 51 harmonics.
- MODBUS-TCP communication.
- 8 GB memory.
- 1GB SD card.
- 8k per second sampling rate.
- recording interval from 1 sec to 9999 secs.
- CSV downloads of data by USB (These can be used to obtain power consumption graphs over time and thus enable accurate sizing of a solar system).

*ME440 Logger is excellent value in SA for power logging and power quality analysis. Mimic gives full technical support and product demonstrations in Gauteng and by special arrangement in other areas.

Displays and logs all of the parameters available on the ME435, which include:

Current, Voltage, Power Factor, Frequency, Active Power, Reactive Power, Max Demand, 8k and many others to accurately analyse a power system.

The Kit: The complete kit is supplied in a robust case with 4 600 Amp Rogowski coils (larger coils are available from Mimic in 5 sizes, to read from 10A up to 7200A at an accuracy of 0.5%). A major advantage of the Meatrol loggers is the use of accurate Rogowski coils as standard (0.5% accurate over a wide range, which is better than a standard CT). They simply clip around the cable cores and thus save a lot of time and expense compared to any other methods of reading Amps.

Mimic supply Rogowski coils for use in Permanent Smart Metering applications.

Specification	
Model	ME435
Product component type	Handheld three phase rogowski power meter
Poles description	3PH4W 3PH3W 1PH2W (L-N); 1PH2W(L-L); 1PH3W(L-L-N)
Device application	Power analysis Data log
Support Extra sensor	4pcs BNC terminal 333mV CT 4pcs BNC terminal Rogowski coil
Display	3.5 inch TFT screen display
Sampling rate	8k samples per second
Harmonic	51th in the mean time
Mechanical characteristics	
Weight	850g (with Accessory 2kgs)
Dimension	L*W*D:21.5*13*6CM
Wire diameter for terminals	
Current input	BNC connector
Voltage input	Banana plug
DC power supply	DC 5.5*2.1 plug
Power Supply	
Power	2*2900mAh PANASONIC lithium battery Working time: 10 hours Charging time: 8 hours 5V DC power supply(included adaptor)



2

ME 435 Poly-Phase Power Network Logging Meter & Kit

Now available for hire or for purchase! Contact us for more information

Mimic Components has released ENERTEQ™ by Meatrol® a cost effective hand held 3-phase power logging meter ideal for power efficiency surveys to solar or other alternative power installations. It is supplied as a complete solution for power requirements that need network analysis.

A big advantage is the use of Rogowski coils and their associated integrators. These are simply placed around cable cores without the need for disconnection. Current sensors are available from 100 amp up to 6000 amps.

Application: Assessing Solar Power Installations.

Electrical power logging meter when converting from electricity to solar to analyse power consumption for correct solar sizing after electric conversion to solar.

Power meter characteristics:

Measurements of current and voltage. Ideal for power efficiency to solar or other power installations.

Cost effective hand held 3-phase power logger.

Complete solution for power requirements that need network analysis.

Includes reports of real-time RMS values for all 3-phases and neutral.

Calculates power factor, Realpower, reactive power harmonics and more.

Stores between 1GB to 6GB of data on an SD card.

Current sensors are available from 100amp up to 6000amps.

Recorded data is measured and displays date & time, voltage (V), Frequency (Hz), PF (power factor),

Active Power (W), Reactive Power (Var), Apparent Power (Va),

Active Energy (Wh), Reactive Energy (Varh) and apparent Energy (Vah).

All readings are displayed on a 3.5 inch quality colour TFT screen and comply with IEC 62053. Voltage measurement accuracy is 0.2% from 100V to 500V and up to 8 variables that can be logged with a sampling rate of 8k samples per second.

The Kit Contains:

1 x power meter, 4 x voltage wires, 1 x power adapter,

1 x 1GB SD card, 3 x Rogowski coils,

1 x USB-to-SD adapter and a robust lockable case.



ME435 Three-phase Handheld Power Meter

Specification	
Model	ME435
Product component type	Handheld three phase rogowski power meter
Poles description	3PH4W 3PH3W 1PH2W (L-N); 1PH2W(L-L); 1PH3W(L-L-N)
Device application	Power analysis Energy meter
Input type	BNC terminal 333mV CT BNC terminal Rogowski coil
Display	3.5 inch TFT screen display
Sampling rate	8k samples per second
Mounting mode	Hand Held
Harmonic	52th Max
Power	4*AA battery(wroking time:approx 7 hours) Or 9V DC power supply(included adaptor)
Display characteristics	
Feature	3.5 Inch TFT screen display 320*480
Mechanical characteristics	
Weight	350g
Dimension	L*W*D:21.5*10*3.5CM
Storage	1GB SD card(Max 4GB)(save intervals 1mins default)

Analyser. Solar Grid Systems.**MQ21 Event Recorder. Power Quality Analyser.****Solar Grid-Connected PV Generation Systems. DIN Rail Mounting.****Application**

Power Quality Analysis and Consumption.

Solar Grid-Connected PV Generation System, Consumption, Event Recorder and Multifunction Fault Recorder.

Event Recording

Acts as an Event recorder to log Dips, Surges and other events.

Event recordings include Event type, Start time, Duration, Amplitude, Voltage RMS half value and Voltage waveform.

Features

Supports systems of single-phase and three-phase. Measures multiple electrical parameters voltage, current, harmonic, energy, power factor and active power on the power grid of phase A, B, C and phase N.

Equipment Temperature

Note that even the equipment temperature can be monitored via three thermocouple inputs (MQ-21 Pro).

Auxiliary Supply

MQ21 requires power which can be obtained from the major loop between 90 and 526 volts AC, or from an optional external Lithium 18650 battery set charged from 230Vac.

Communication

Standard communication configurations such as of RJ45 and RS485 interfaces.

Standard MODBUS TCP and MODBUS RTU protocols.

MQ21 is compatible with various configuration systems and transmits the electrical parameters collected by the front end to a selected point in real time via Modbus. Data can be stored onto a 16 G Micro SD card and downloaded by USB.

Optional: It can also be connected to the Internet via optional MQ-21-4G Gateway.

Connections

Two models are offered:

1. Type C which uses Standard CT s.
2. Type R which uses open ended Rogowski clip on coils (available in 3 sizes: 600Amp. 3000Amp and 6000Amp). These clip coils are very accurate (0.5% full scale) and extremely convenient as there is no disconnection of the main power supply, and often there is no need to do plant shut-downs.

Mounting

DIN Rail mounting



MQ21-4G Edge Processing Gateway

Application

- MQ21-4G is used to connect the MQ21 device to the Internet via a mobile phone network.
- Works with other intelligent power acquisition equipment and electricity meters.
- Suitable for energy consumption monitoring and power quality analysis of electrical parameters.
- Collects waveform data and event data in real time.
- Analyses power in real time.

Product Description

- The MQ21-4g edge processing gateway is a Gateway that integrates remote transmissions.
- Incorporates 4G full Netcom functions.
- Outer material is Aluminium alloy shell, small and convenient to carry on business trips.
- A 35mm guide rail buckle is set to facilitate on-site installation.

Features

- Supports 4G full Netcom and fast networking capabilities.
- Wireless transmission function and supports device data on the cloud.
- Support Modbus TCP to 4G.
- Expansion function supports up to 10000 devices on the Cloud.
- Edge computing function & built-in edge computing processing unit that greatly reduces transmission of redundant information.
- Designed with Aluminium alloy shell which is small and easy to carry.
- Real-time waveform and event waveform acquisition. Cloud Supported.

Customization Features

It has an edge processing extension function, a built-in edge processing unit and specific parameter monitoring and alarm mechanism.

Specification

Model	MQ21_4G
Function	MODBUS TCP to 4G
Port	RJ45
Power supply	(Suggest) DC 5V 2A
Power waste	1.6W
Support	4G
Dimensions	107 (±1) mm*50 (±1) mm*29 (±1) mm
Working temperature	-20~85 °C
Storage temperature	--40~85°C
Installation method	Clamp rail installation



PQ-4G Ethernet Edge Computing Gateway

Application

Ethernet edge computing Gateway. 4G Gateway Wireless Transceiver Module and Wireless Radio Modules. Can also be used with and operates with intelligent power acquisition equipment and electricity meters. It is suitable for energy consumption monitoring and power quality analysis of electrical parameters, collects waveform data and event data in real time, and analyses the power via Cloud in real time.

Features

- * Supports 4G full Netcom and fast networking.
- * It has wireless transmission functions and supports device data in the Cloud.
- * Support MODBUS TCP to 4G.
- * It has expansion capability to support 10,000 devices in the Cloud.
- * It has edge computing functions
- * Built-in edge computing processing unit to greatly reduce the transmission of redundant information.
- * Outer design material Aluminium alloy shell which is small and easy to carry.
- * Supports real-time waveform and event waveform acquisition.

Customization Features

Edge processing extension functions, built-in edge processing unit, specific parameter monitoring and alarm mechanism.

Configurations

PQ-4G Gateway Configures with ME440 power quality analyser for online power monitoring.

SPECIFICATIONS

Model	PQ-4G
Type	2/2.5/3/4G Module, Data Terminal Unit, Wireless radio modules
Brand	MEATROL
Chip	Air724UG
Function	MODBUS TCP to 4G
Port	RJ45
Power supply	(Suggest)DC 5V 2A
Power waste	1.6W
Support	4G
Dimensions	107*50*29mm
Working temperature	-20~85 °C
Storage temperature	-40~85°C
Installation method	Clamp rail installation

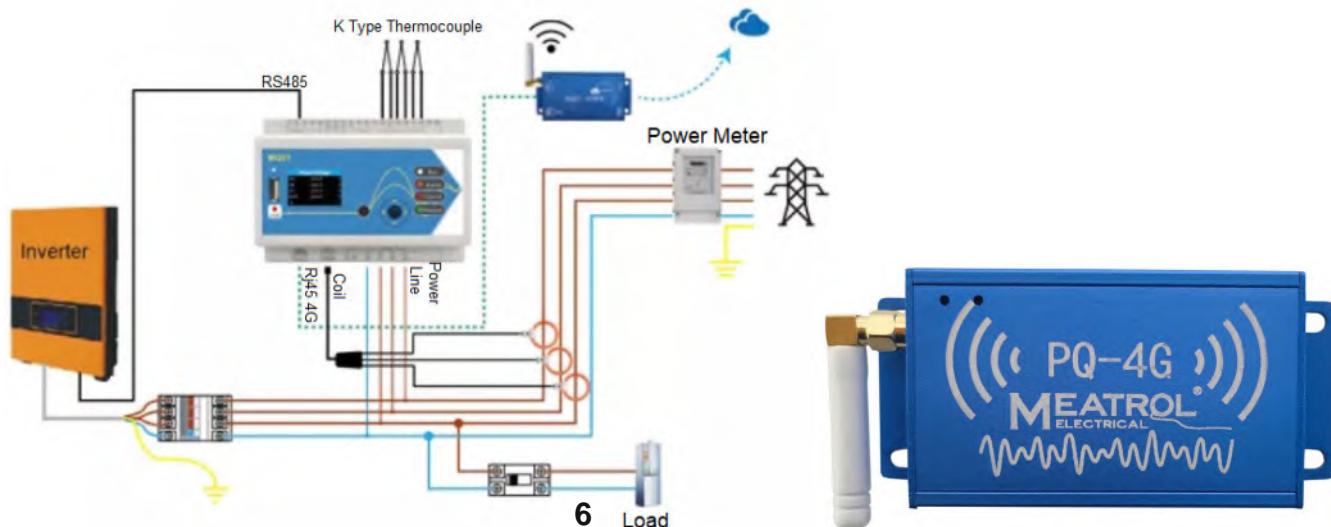

4G Module and Energy Quality Monitoring Platform

Product Requirements, Usages & Platform

Supports all Meatrol Meters.
 MODBUS TCP to 4G requires model type Mtcp_4G on Port RJ45.
 MODBUS RTU to 4G requires model type Mrtu_4G on Port RJ45.
 Cloud supported On-Line Energy Quality Monitoring Platform.
 User Login & User Real-time Online EQMP
 (Energy Quality Monitoring Platform).
 *Short Form Data Sheet on the
 Process of Usage of the PQ-4G Gateway available on request.



PQ-4G Supports all Meatrol Products

Model	Mtcp_4G	Mrtu_4G
Function	MODBUS TCP to 4G	MODBUS RTU to 4G
Port	RJ45	
Power supply	DC 5V 2A	
Power dissipation	Max 8W	
Support	4G	
Weight	98g	
Dimension	89.5 (±1) mm*80 (±1) mm*25 (±1) mm	
Operating temperature	-20~85 °C	
Storage Temperature	-40~85°C	
Installation	M4 Screw fixation	

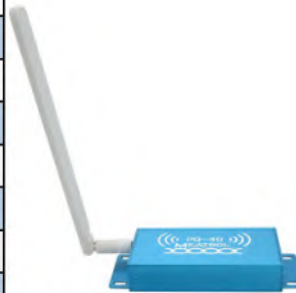

PQ-4G Product Requirements
 MODBUS TCP to 4G needs model type Mtcp_4G
 MODBUS RTU to 4G needs model type Mrtu_4G



PQ-4G
 Cloud supported Online Energy Quality Monitoring User Platform.

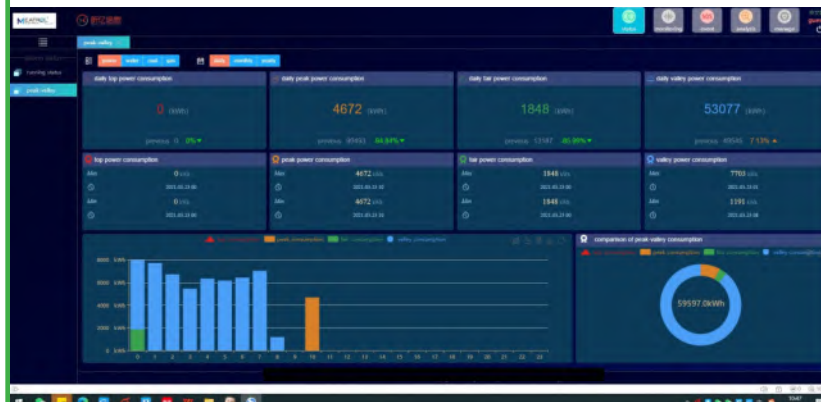

PQ-4G
 Real-Time On-Line EQMP (Energy Quality Monitoring Platform).
 Detailed Screen Monitor Display with data information.

TABLE

Power Meters: ME437 : ME631 : ME53

Three-Phase Power Meters

Specification			
Model	ME437-SD	ME631-SD	ME531
Product component type	Multifunction power meter		
Poles description	3PH4W 3PH3W 1PH2W (L-N); 1PH2W(L-L); 1PH3W(L-L-N)		
Device application	Power analysis Energy meter		
Input type	External CT(333mV only) And External Rogowski coil		
Display	3.5 inch TFT screen display	2.0 inch TFT screen display	None LCD display
Sampling rate	8k samples per second		
Mounting mode	Panel mounting	DIN rail	
Harmonic	52th Max		
Display Characteristics			
Feature	320*480 dots	39mm x 32mm 220 x 170 dots	N/A
Mechanical Characteristics			
Weight	350g	212g	125g
Dimension	L*W*D:96*96*99mm	L*W*D:76*95*71mm	L*W*D:122*87*23mm
Storage	1GB SD card(Max 4GB)(save intervals 1mins default)		None
Measurement Accuracy			
Model	ME437-SD and ME531		ME631-SD
Rated current	100A(0.5% from 10A to 120A) 600A(0.5% from 10A to 720A) 1000A(0.5% from 10A to 1200A) 3000A(0.5% from 30A to 3600A) 6000A(0.5% from 60A to 7200A)		Only choice one point, accept OEM
Rogowski coil specification	100A	MRC-16	85mV/kA@50H ± 0.5%
	600A	MRC-36	
	1000A	Y-FCT-200 or Y-FCT-350 or NRC-100	50mV/kA@50H ± 0.5%
	3000A	NRC-150 or Y-FCT-510	
	6000A	NRC-200 or Y-FCT-800	
Voltage	0.2% from 100V to 500V(L-L and L-N)		
Power factor	± 0.005 from 10% to 120%		
Active/Apparent Power	IEC62053-22 Class 0.5		
Reactive power	IEC62053-21 Class 2		
Frequency	0.01% from 45 to 65Hz		
Active energy	IEC62053-22 Class 0.5s		
Reactive energy	IEC62053-21 Class 2		
Measurement Range			
Measured voltage	100V to 500V AC		
Frequency range	50/60Hz		
Input-current Characteristics			
Primary current range	Adjustable from 0.1A to 9999A		
Measurement input range	1/225mV-333mV		
Permissible overload	600mV for 10s/hours		

TABLE : Function List Page i
Power Meters: ME437 : ME631 : ME531
Three-Phase Power Meters

FUNCTION LIST			● YES	○ OPTION	BLANK: NO				
FUNCTION		PARAMETER	ME440	ME435	ME531	ME631	ME437		
Specific	5 Rated Current Selectable	100A/600A/ 1kA/3kA/6kA	100A connect to MRC-24 50mV/kA@50Hz						
			600A connect to MRC-36 50mV/kA@50Hz		●	●			
	3 Rated Current Selectable	600A//3kA/ 6kA	1kA connect to NRC-100 85mV/kA@50Hz						
			3kA connect to NRC-150 85mV/kA@50Hz				●		
	Display	TFT color display	6kA connect to NRC-200 50mV/kA@50Hz						
			600A connect to MRC-36 50mV/kA@50Hz	●					
	Install Style	Handheld Type	3kA connect to NRC-150 85mV/kA@50Hz		●				
			6kA connect to NRC-200 50mV/kA@50Hz		●				
			Panel Type				●	●	
	Powersupply	2*2900mAh PANASONIC lithium battery	DIN-RAIL Type			●	●		
			4*AA battery	●	●				
			85-265VAC/DC			●	●	●	
	Full parameter record	8GB memory	24V DC			●			
			SD Card	1GB	●	●	○	○	
Communi-cation	Communication protocol	5VDC adaptor	●	●					
		RJ45-Modbus-TCP	●		●	●	●		
Measur-ement	Real-Time Parameter	RS485-Modbus-RTU			●	●	●		
		Voltage	Ua Ub Uc, avg	●	●	●	●	●	
				PE-N Voltage	Ue	●			
						Current	Ia Ib Ic, avg	●	●
				Neutral Current	In			●	
						Active Power	Pa,Pb,Pc,Psum	●	●
				Reactive Power	Qa,Qb,Qc,Qsum			●	●
						Apparent Power	Sa,Sb,Sc,Ssum	●	●
	Power Factor			PFa,PFb,PFc,avg	●			●	●
		Frequency	Fa,Fb,Fc,avg		●	●	●	●	
	Electric energy measuring			Active Energy	EPa,EPb,EPc,EPsum	●	●	●	●
		Reactive Energy	EQa,EQb,EQc,EQsum			●	●	●	●
						Apparent Energy	ESa,ESb,ESc,ESSum	●	●
	Demand	Demand (some time ago)	Current Ia Ib Ic, avg	●	●				●
Maximum Demand (Maximum value of Demand)				Active/Reactive/Apparent Power ABCPsum,Qsum, Ssum	●	●		●	
					●	●			

TABLE : Function List page ii
Power Meters: ME437 : ME631 : ME531
Three-Phase Power Meters

FUNCTION LIST								
Power Quality	Harmonic	Current harmonic value	ITHDa, ITHDb, ITHDc,	•	•	•	•	•
		Current harmonic percentage	ITHDa(%), ITHDb(%), ITHDc(%)	•	•	•	•	•
		Voltage harmonic value	UTHDa, UTHDb, UTHDc	•	•	•	•	•
		Voltage harmonic percentage	UTHDa(%), UTHDb(%), UTHDc(%)	•	•	•	•	•
	Harmonic number display	52 times meanwhile (percentage)		•				
		5 times meanwhile (percentage)			•			
		3 times meanwhile (percentage)					•	•
	Time-sharing Measurement	3 Tariff	Controlled by modbus				•	
	Current Unbalance	Each phase, Most Unbalance phase	Ubl(Ia, Ib, Ic, Iwst)	•	•			
	Voltage Unbalance	Each phase, Most Unbalance phase	Ubl(Ua, Ub, Uc, Uwst)	•	•			
	Line Voltage		Uab Ubc Uac	•	•		•	•
	Voltage Angle		Uab Ubc Uac	•	•			•
	Current Angle		Uab Ubc Uac	•	•			•
	Displacement Power Factor	Each phase, total	DPFa, DPFb, DPFc, TOT	•	•			
	Instantaneous Maximum RMS	Current	Ia Ib Ic, avg	•	•			
		Voltage	Ua Ub Uc, avg	•	•			
Power		Pa, Pb, Pc, Qa, Qb, Qc, Sa, Sb, Sc, Psum, Qsum, Ssum	•	•				
Instantaneous Minimum RMS	Current	Ia Ib Ic, avg	•	•				
	Voltage	Ua Ub Uc, avg	•	•				
	Power	Pa, Pb, Pc, Qa, Qb, Qc, Sa, Sb, Sc, Psum, Qsum, Ssum	•	•				

Rogowski Coils -Introduction

INTRODUCTION TO ROGOWSKI COILS

What is a Rogowski coil?

Rogowski coils have been used for the detection and measurement of electric currents for decades. They are based on a simple principle: an "air-cored" coil is placed around the conductor in a toroidal fashion and the magnetic field produced by the current induces a voltage in the coil.

The voltage output is proportional to the rate of change of current. This voltage is integrated, thus producing an output proportional to the current. By using precision winding techniques, developed especially for purpose of use, the coils are manufactured so that their output is not influenced by the position of the conductor within the toroid, in addition to rejecting interference from external magnetic fields caused, for example; from nearby conductors.

Basically, a Rogowski coil current measuring system consists of a combination of a coil and conditioning electronics. Rogowski coil current transducers are used for the AC measurement. They can be used similarly to current transformers but with considerable advantages:

Advantages

- Wide dynamic range.
- High linearity.
- Very useful with large size or awkward shaped conductors or in places with limited access.
Thanks to its non-hardcore structure, the coil can be easily manufactured according to the application or to the available space.
- Unlike traditional current transducers, there is no danger from open-circuited secondaries. They cannot be damaged by large overloads.
- They are non intrusive. They draw no power from the main circuit carrying the current to be measured.
- They are light weight and in some applications are light enough to be suspended on the conductor being measured.
- The transducer does not measure direct currents but, unlike a current transformer, it can carry out accurate measurements of AC components even if there is a large superimposed DC component since there is no iron core causing saturation. This feature is particularly useful for measuring ripple currents, for example; in battery charging systems.

Features

- Y-FCT and FCT are flexible current transducers and RCT is a rigid current transducer which, based on the Rogowski principle, is particularly suitable for measurements in combination with portable devices.
- Coils are available in different sizes and can be supplied according to customer's design. Therefore they can be used in many applications in which traditional transducers do not fit due to size and/or weight.
- Due to its specific features, flexible Rogowski coils are an ideal solution for current measurement and can be used in a number of cases where traditional current transducer do not supply an adequate solution.
- Coils provide a shield against the influence of external magnetic fields, granting a stable measurement from low currents to hundreds of kA.
- The Rogowski coils must be connected to an electronic integrator for 90° phase shift compensation and frequency equalization.
- The Meatrol DIN-RAIL and panel meters interface with Rogowski coils directly without the need of other external integrators.
This is advantageous limiting external boxes and other power supply for ease of use.
- The particular feature of the Rogowski coil combined with an extremely flexible input programming of Meatrol's portable meters, allow the user to carry out measurement of many applications.

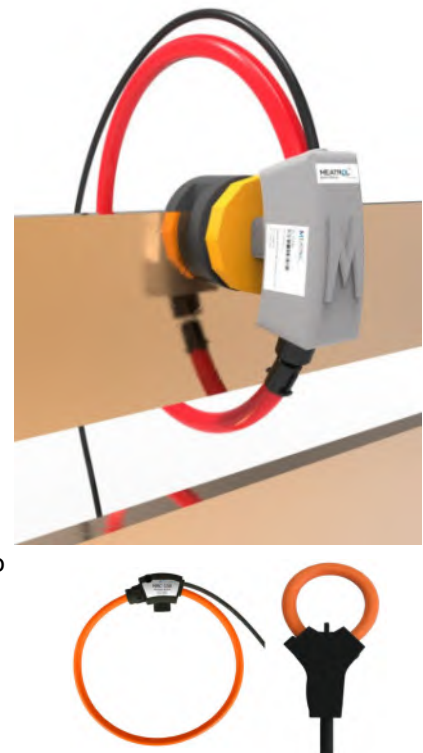

Rogowski Coils Model Types

MRC

MRC Flexible Rogowski Coil fixed by cable ties.

MRC Ø6 Flexible Rogowski Coil Fixed by Cable Ties.**Features**

High linearity from 1A to 1000A .
 Wide dynamic range.
 Very useful with large size or awkward shaped conductors and in places with limited access.
 No danger from open-circuited secondaries.
 Not damaged by large overloads.
 Non-intrusive, no power drawn from the mains.
 Measurement uniformity in any position of the conductor inside the coil.
 Excellent degree of rejection to external current conductors.

Advantages

- Calibrated to 0.5%.
- 6mm section for more stability.
- Easy to fix on bus-bar, cable or by cable ties.
- Very competitive price.

Related Products

S1, D1, S9, SW, A01, A05 ,ME631, ME437.

Applications

Measuring devices, lab instrumentation.
 •Power monitoring & control systems.
 •DC ripple measurement.
 •Harmonics and transients monitoring.
 •Power meter, Power analyser sensor.

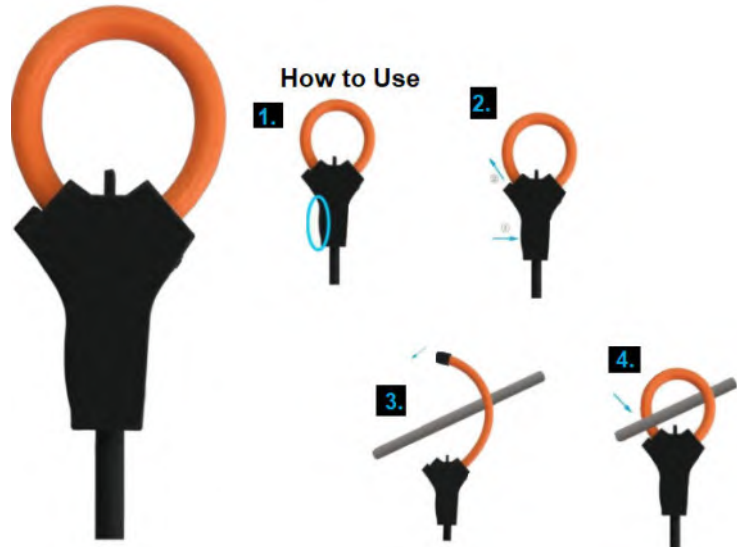

Rogowski Coils Model Types

Y-FCT

Y-FCT Flexible Rogowski Coil

Y-FCT 08 Flexible Rogowski Coil**Features**

High linearity from 1A to 100kA
 Wide dynamic range.
 Very useful with large sized or awkward shaped conductors and in places with limited access.
 No danger from open-circuited secondaries.
 Not prone to damage by large overloads.
 Non-intrusive, no power drawn from the mains.
 Measurement uniformity in any position of the conductor inside the coil.
 Excellent degree of rejection to external current conductors.

Advantages

- Calibrated to 0.5%. •8mm section easy to install
- Two layers shielded •Lower zero drift down to 0.05mV

Related Products

S1 D1 S9 A01 A05 SW ME631 ME437

Applications

•Measuring devices, lab instrumentation
 •Power monitoring & control systems
 •DC ripple measurement
 •Harmonics and transients monitoring
 •Power meter, Power analyser sensor

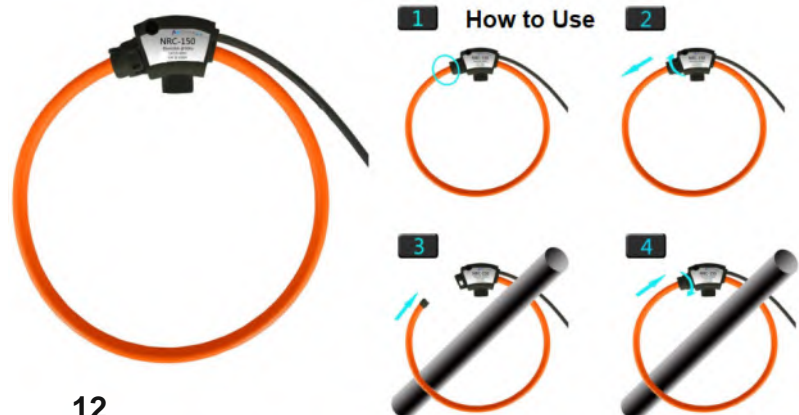

12

Integrators (Amplifiers)

What does an Integrator do?

•As the Rogowski coil output is a weak voltage mV signal, an integrator is used for its ability to amplify and convert a weak voltage mV signal to a standard signal when used with a multi-meter and scope. Mimic supply two multi-meter models:

- (1) ME237R which accepts Rogowski coils input directly and
- (2) ME237C which accepts a standard CT input, so there is no need to use an integrator when using these two types of multi-meters.

•Rogowski coil output is proportional to the frequency of the measured current. The signal equalization via an integrator ensures a linear response on a wide frequency range. It allows the use of coils on different electrical network frequencies, keeping the same output level over the frequencies.

•An integrator is essential to equalize and shift by 90° the output signal from the Rogowski coils. It consists of an active electronic circuit with negligible offset and a good linearity.

S9 Mini Integrator

S9

S9 Mini Integrator

S9 is a mini Rogowski coil integrator combined with a power meter or PLC, in a plastic enclosure, powered directly from the mains.

Feature

S9 can be combined with any model and size of Y-FCT or NRC Rogowski coils.

The available values are: 0-10VDC, 0-10Vrms, 333mVrms.

On request the input value can be customized according to the application.

S9 and Rogowski coil is a very flexible system, suitable for high power load analysis, impulsive current monitoring, DC ripple measurement, etc.

Due to its specific features, flexible Rogowski coil is an extremely comfortable solution for current measurement and can be used in a number of cases where traditional current transducer is not the adequate solution.

Advantage

- High read accuracy 0.5%
- Smart volume for limited space installation
- Low power consumption
- Lower zero drift down to 5mV

Related Products

Y-FCT NRC MRC ZRC RCT

Applications

Measuring devices

- Power meter measurement
- Harmonics and transients monitoring
- Welding machine control
- High current measurement
- PLC control

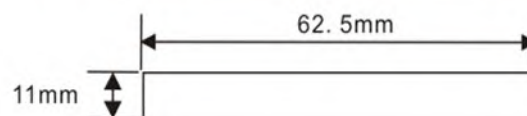

S9.4 Waterproof Integrator

S9.4 Waterproof integrator

S9.4 is a waterproof Rogowski coil integrator combined with a power meter or PLC, in a plastic enclosure, powered directly from the mains.

Features

S9 can be combined with any model and size of Y-FCT, MRC or NRC Rogowski coils.

The available values are: 4-20mADC. On request the input value can be customized according to the application.

S9 and Rogowski coil is a very flexible system, suitable for high power load analysis, impulsive current monitoring, DC ripple measurement, etc.

Due to its specific features, flexible Rogowski coil is an extremely comfortable solution for current measurement and can be used in a number of cases where traditional current transducer is not the adequate solution.

Advantage

- High read accuracy 0.5%
- Smart volume for limited space installation
- Low power consumption
- IP68

Related Products

Y-FCT, MRC, NRC, ZRC

Applications

Measuring devices

- Power meter measurement
- Harmonics and transients monitoring
- Welding machine control
- High current measurement
- PLC control



D1 Industrial Integrator

D1

D1 Industrial integrator

D1 is an Industrial Rogowski coil integrator installation in distribution box, in a plastic 1 module DIN-RAIL enclosure, powered directly from the mains.

Features

D1 can be combined with any model and size of Y-FCT or NRC Rogowski coils.

The available values are: 0-5VDC, 0-5VAC, 4-20mAC.

On request the input value can be customized according to the application.

D1 and Rogowski coil is a very flexible system, suitable for high power load analysis, impulsive current monitoring, DC ripple measurement, etc.

Due to its specific features, flexible Rogowski coil is an extremely comfortable solution for current measurement and can be used in a number of cases where traditional current transducer is not the adequate solution.

Advantage

- High read accuracy 0.5%
- Easy to install with DIN-RAIL
- High bandwidth for measurement 5 to 20kHz
- Lower zero drift down to 2mV

Related Products

Y-FCT, ZRC, NRC, MRC

Applications

Measuring devices

- Power monitoring & analysis
- Harmonics and transients monitoring
- Welding machine control
- High current measurement
- PLC control

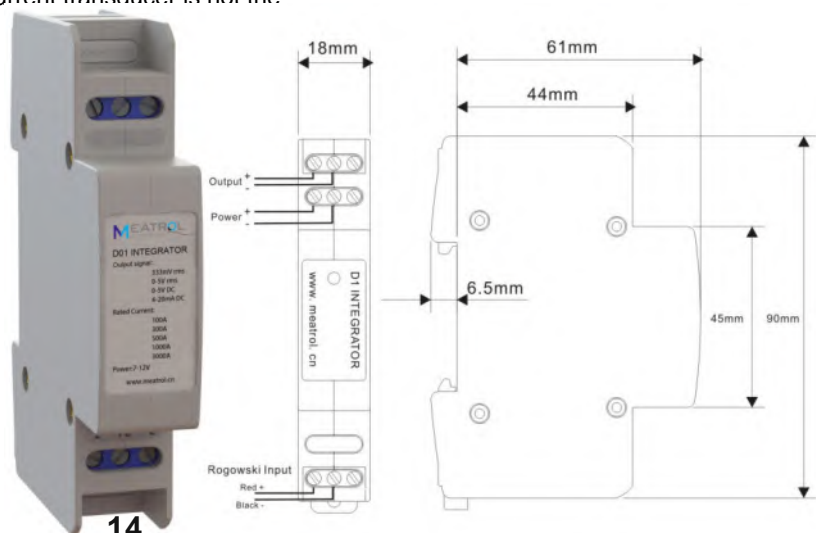

14

S1 High Accuracy Integrator

S1 High Accuracy integrator

S1 is a High Accuracy Rogowski coil integrator, in a compact shield aluminium alloy enclosure, powered directly from the mains.

Features

S1 can be combined with any model and size of Y-FCT or NRC Rogowski coils.

The available values are: 0-10VDC, 0-10V peak, 4-20mA.

On request the input value can be customized according to the application.

S1 and Rogowski coil is a very flexible system, suitable for high power load analysis, impulsive current monitoring, DC ripple measurement, etc.

Due to its specific features, flexible Rogowski coil is an extremely comfortable solution for current measurement and can be used in a number of cases where traditional current transducer is not the adequate solution.

Advantage

- High read accuracy 0.2%
- Wide power supply arranged -12VDC or 24VDC
- High bandwidth form measurement 5 to 20kHz
- Lower zero drift down to 1.5mV

Related Products

Y-FCT, MRC, NRC, ZRC

Applications

Measuring devices, lab instrumentation

- Power monitoring & control systems
- Harmonics and transients monitoring
- DC ripple measurement
- Welding machine control
- High current measurement

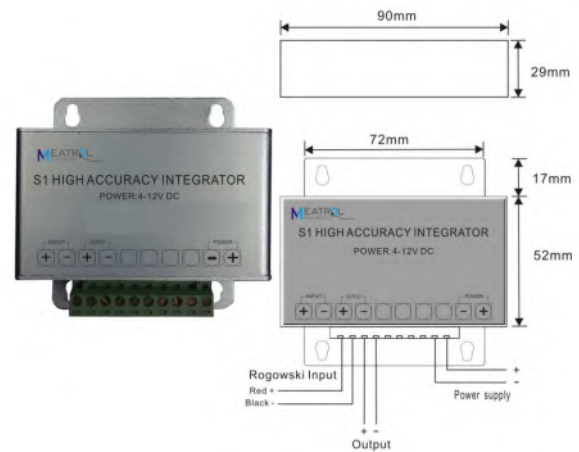

DTP Integrator

DTP

DTP integrator

DTP is a THREE-PHASE IN-RAIL Vac/dc Output Rogowski coil integrator installation in distribution box, in a plastic 1 module DIN-RAIL enclosure, powered directly from the mains.

Features

DTP can be combined with any model and size of Y-FCT or NRC Rogowski coils.

The available values are: 333mV, 5V AC rms.

On request the input value can be customized according to the application.

DTP and Rogowski coil is a very flexible system, suitable for high power load analysis, impulsive current monitoring, DC ripple measurement, etc.

Due to its specific features, flexible Rogowski coil is an extremely comfortable solution for current measurement and can be used in a number of cases where traditional current transducer is not the adequate solution.

Advantage

- High read accuracy 0.5%
- Compact DIN-RAIL construction
- Low power consumption
- Lower zero drift down to 5mV

Related Products

Y-FCT, ZRC, NRC, MRC

Applications

Measuring devices, and lab instrumentation.

- Power monitoring & analysis.
- Harmonics and transients monitoring.
- Welding machine control.
- High current measurement.

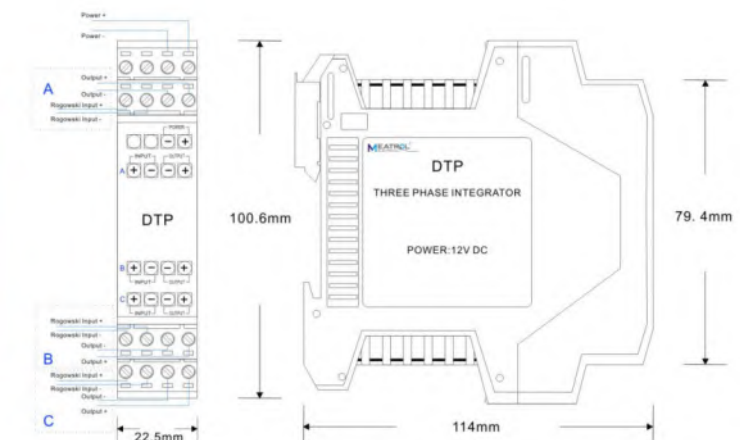

15

Integrators (Amplifiers)

DA01

DA01 Integrator

DA01 integrator

DA01 is a DIN-RAIL 1A Output Rogowski coil integrator installation in distribution box, in a plastic 1 module DIN-RAIL enclosure, powered directly from the mains.

Features

DA01 can be combined with any model and size of Y-FCT or NRC Rogowski coils.

The available values are: 0-1AAC.

On request the input value can be customized according to the application.

DA01 and Rogowski coil is a very flexible system, suitable for high power load analysis, impulsive current monitoring, DC ripple measurement, etc.

Due to its specific features, flexible Rogowski coil is an extremely comfortable solution for current measurement and can be used in a number of cases where traditional current transducer is not the adequate solution.

Advantage

- High read accuracy 0.5%.
- Compact DIN-RAIL construction.
- High bandwidth for measurement 30 to 5kHz • Output 1A rms.

Related Products

Y-FCT, ZRC, NRC, MRC

Applications

Measuring devices, and lab instrumentation.

- Power monitoring & analysis.
- Harmonics and transients monitoring.
- Welding machine control.
- High current measurement.

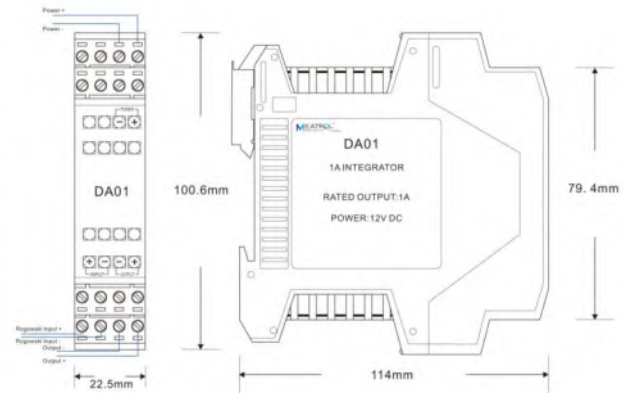

ATP01 Integrator

ATP01

ATP01 integrator

ATP01 is a Three-phase DIN-RAIL 1A Output Rogowski coil integrator installation in distribution box, in a plastic 1 module DIN-RAIL enclosure, powered directly from the mains.

Features

ATP01 can be combined with any model and size of Y-FCT or NRC Rogowski coils.

The available values are: 0-1AAC.

On request the input value can be customized according to the application.

ATP01 and Rogowski coil is a very flexible system, suitable for high power load analysis, impulsive current monitoring, DC ripple measurement, etc.

Due to its specific features, flexible Rogowski coil is an extremely comfortable solution for current measurement and can be used in a number of cases where traditional current transducer is not the adequate solution.

Advantage

- High read accuracy 0.5%.
- Compact DIN-RAIL construction.
- High bandwidth for measurement 30 to 5kHz • Output 1A rms.

Related Products

Y-FCT, ZRC, NRC, MRC

Applications

Measuring devices, lab instrumentation

- Power monitoring & analysis
- Harmonics and transients monitoring
- Welding machine control
- High current measurement

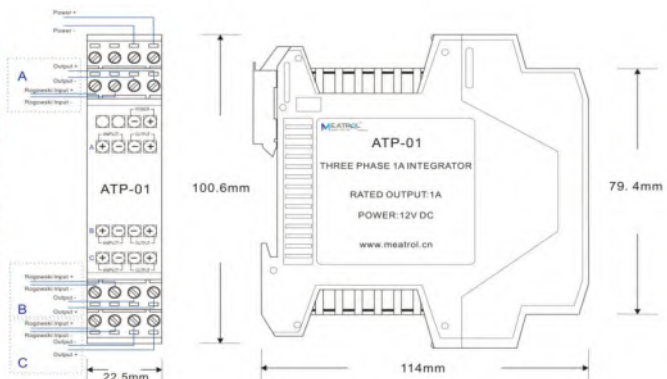

A05 Integrator

A05 integrator

A05 is a 5A output Rogowski coil integrator, in a shield aluminium alloy enclosure, powered from 2pcs SMPS (switch module power supply).

Features

A05 can be combined with any model and size of Y-FCT or NRC Rogowski coils.
The available values are: 0-5AAC.

On request the input value can be customized according to the application.

A05 and Rogowski coil is a very flexible system, suitable for high power load analysis, impulsive current monitoring, DC ripple measurement, etc.

Due to its specific features, flexible Rogowski coil is an extremely comfortable solution for current measurement and can be used in a number of cases where traditional current transducer is not the adequate solution.

Advantage

- High read accuracy 0.5%.
- High linearity 0.2%.
- High bandwidth for measurement 30 to 5kHz • Output 5A rms.

Related Products

Y-FCT, ZRC, NRC, MRC

Applications

Measuring devices, lab instrumentation.

- Power monitoring & analysis.
- Harmonics and transients monitoring.
- Welding machine control.
- High current measurement.

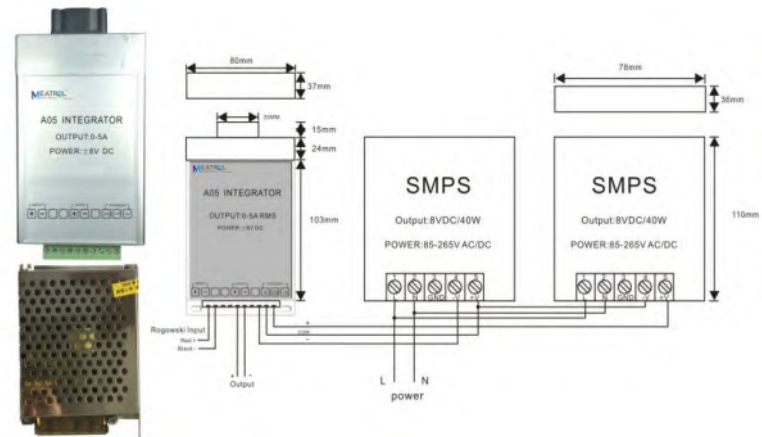

HF High Frequency Integrator

HF High Frequency

HF High Frequency integrator

HF is a High Frequency Rogowski coil integrator, in a compact shield aluminium alloy enclosure, powered directly from the mains. It provides the measurement of all kinds of waveforms like 3/5Ms, 8/20IJs, 10/350us, frequency from 100kHz to 1MHz, it also features in direct connection to oscilloscope.

Features

HF can be combined with any model and size of H-FCT Rogowski coils.

The available values are: 0-12V peak.

On request the input value can be customized according to the application.

HF and Rogowski coil is a very flexible system, suitable for high power load analysis, impulsive current monitoring DC ripple measurement, etc.

Due to its specific features, flexible Rogowski coil is an extremely comfortable solution for current measurement and can be used in a number of cases where traditional current transducer is not the adequate solution.

Advantage

High read accuracy 2%.

- Wide power supply arrange: 4-12VDC "1/5Ms, 8/20Ms, 10/350us waveform restore.
- Up to 500kA lightning current measurement.

Related Products

H-FCT

Applications

Measuring devices, and lab instrumentation.

- Lightning protection.
- Lightning monitoring.
- Lightning current measurement.
- Pulse waveform analysis.

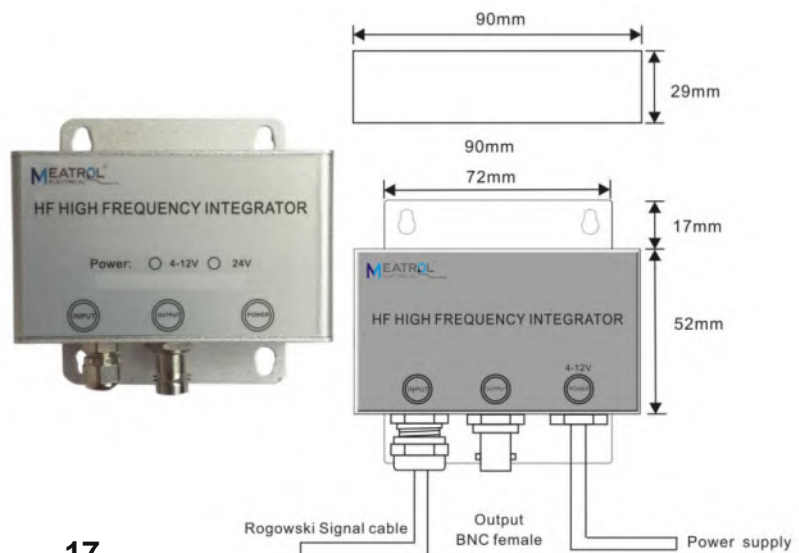

S2 Integrator

S2 integrator

S2 is a Single-phase two rated current handheld Vac/dc Output Rogowski coil integrator connect to power analyser, in a plastic mini enclosure, powered by battery or DC adaptor.

Features

S2 can be combined with any model and size of NRC, MRC, Y-FCT Rogowski coils.

The available values are: 3 Vac.

On request the input value can be customized according to the application.

S2 and Rogowski coil is a very flexible system, suitable for high power load analysis, impulsive current monitoring, DC ripple measurement, etc.

Due to its specific features, flexible Rogowski coil is an extremely comfortable solution for current measurement and can be used in a number of cases where traditional current transducer is not the adequate solution.

Advantage

High read accuracy 0.5%

- Mini handheld
- Low power consumption
- Lower zero drift down to 5mV

Related Products

Y-FCT, NRC, MRC

Applications

Measuring devices, lab instrumentation.

- Power monitoring & analysis.
- Harmonics and transients monitoring.
- Welding machine control.
- High current measurement.

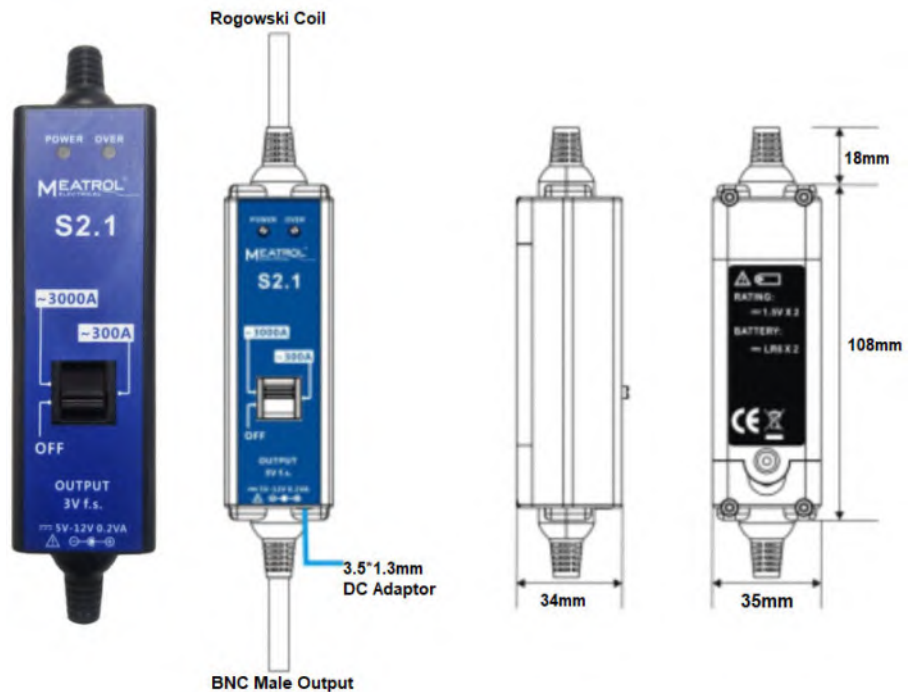

JOHANNESBURG



MIMIC COMPONENTS

ELECTRICAL & ELECTRONIC
WHOLESALE DISTRIBUTORS
SOUTHERN AFRICA

Address

5 Ramsay Street, Booyens,
2091 Johannesburg,
South Africa

P.O. Box 38493 Booyens,
2016 South Africa

Telephone

Switchboard: +27 (0)11- 689-5700
Fax: +27 (0)11- 493-8821

Email: sales@mimic.co.za

Website: www.mimic.co.za



MIMIC COMPONENTS sales@mimic.co.za www.mimic.co.za TEL: (011) 689-5700
5 Ramsay Street, Booyens 2091, Johannesburg FAX: (011) 493-8821

CAPE TOWN



MIMIC CAPE

ELECTRICAL & ELECTRONIC
WHOLESALE DISTRIBUTORS
SOUTHERN AFRICA

Address

Unit 41A, Stella Park,
57 Stella Road, Montague Gardens,
Cape Town, 7441, South Africa

PO. Box 36955 Chempet,
7442 South Africa

Telephone

Switchboard: +27(0) 21-551-8185
Facsimile: +27(0) 21-551-8169

Email: anje@mimics.co.za

Website: www.mimic.co.za



MIMIC CAPE anje@mimics.co.za www.mimic.co.za TEL: +27(0)21-551-8185 FAX: +27(0)21-551-8169
Unit 41A, Stella Park, 57 Stella Road, Montague Gardens, Cape Town 7441. PO Box 36955 Chempet 7442 South Africa